

N 90, Downdraft hood, 90 cm, clear glass
198WMM1S1B

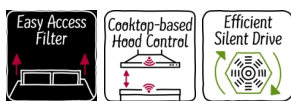

COOKING PASSION SINCE 1877



The Glass Draft Hood seamlessly integrates into the kitchen, with ability to install behind the hob for a single surface look and clear glass panel when in use. Powered by new Guided Air technology for effective extraction, and Climate Control Sensor to optimise the power and noise levels as you cook.

- ✓ Guided Air Technology – Equally powerful steam extraction all over the cooktop regardless of the pans' or pots' location
- ✓ Easy Access Filter – A simple push of a button is enough to remove the easy access filter for a good wash in the dishwasher
- ✓ High Extraction Rate – ensures a clear view while cooking thanks to an efficient motor technology
- ✓ Cooktop-based Hood Control – Adjust your hood's extraction level and lighting.
- ✓ Efficient Drive Motor – Quiet and energy-efficient hood motor for a calmer kitchen.

Features

Technical Data

Typology : Downdraft
 Approval certificates : CE, E17D UKCA marking, VDE
 Length of electrical supply cord : 130 cm
 Required niche size for installation (HxWxD) : 703mm x 854.0mm x 123mm mm
 Net weight : 41.2 kg
 Type of control : Electronic
 Number of speed settings : 3-stage + 2 intensive
 Maximum output air extraction : 519 m³/h
 Boost position output recirculating : 596 m³/h
 Maximum output recirculating air : 456 m³/h
 Boost position air extraction : 833 m³/h
 Noise level : 62 dB(A) re 1 pW
 Diameter of air outlet : 150 mm
 Grease filter material : Washable stainless steel
 EAN code : 4242004262855
 Connection rating : 300 W
 Fuse protection : 10 A
 Voltage : 220-240 V
 Frequency : 50; 60 Hz
 Plug type : GB plug
 Installation type : Built-in

Optional accessories

Z861SB1	90° flat duct bend horizontal
Z861SB2	90° flat duct L vertical
Z861SI0	Adapter round-flat
Z861SI1	90° Adapter round-flat
Z861SM1	Straight tube 500mm
Z861SM2	Straight tube 1000mm
Z861SS1	Connector sleeve (female)
Z92WW1X7	Clean Air Plus recirculation kit
Z92WWJ12	Long Life recirculation kit
Z92WWM11	Installation kit remote motor
Z92WWY9X2	Mounting kit for seamless installation



Features

Connectivity

- Remote Monitoring and Control for connected home appliances and operation via smartphone or tablet (only in countries where Home Connect service is available)
- The Home Connect functionality can be extended by integrating numerous applications from external cooperation partners (partnerships)
- Voice Control enabled via popular voice assistants (only in countries where this service is available)
- Interval function: available via Home Connect
- Silence function: available via Home Connect

Features

- Fully automatic hood
- Hob-Hood control (with Wi-Fi enabled hob)
- climateControl Sensor
- 3 power levels and 2 intensive settings
- Touch control
- The standard functions are located on the right-hand user interface
- Efficient BLDC technology
- Automatic intensive revert (6mins)
- Automatic after running (Automatic after running (10 minutes))
- 2 metal grease filter cassettes
- Saturation indicator for metal and charcoal filter
- The filter service button automatically lifts filters into service position for easy removal

Design

- 90 cm wide
- Installation: integrated
- The glass panel can be easily removed and cleaned
- Suitable for installation in an island or Semi-island kitchen solution

Performance

- Suitable for ducted extraction and recirculation
- For recirculated extraction Clean Air Plus recirculation kit (accessory) needed
- Extraction rate according to EN 61591 ø 15 cm:
max. Normal use 519 m³/h
Intensive 833 m³/h
- Noise level according to EN 60704-3 and EN 60704-2-13 exhaust air:
Max. normal use: 62 dB(A) re 1 pW
Intensive: 71 dB(A) re 1 pW
- With the Clean Air Plus recirculation kit (available as optional accessory) your appliances reaches:
Extraction rate in recirculation mode:
Max. normal use: 456 m³/h
Intensive: 596 m³/h
Noise level in recirculation mode:
Max. normal use: 66 dB(A) re 1 pW
Intensive: 71 dB(A) re 1 pW

Planning and installation information

- Extension height 250 mm
- Dimensions (HxWxD): 709 x 918 x 140 mm
- Built-in dimensions (HxWxD): 703 x 854 x 123 mm
- Extractor hose 150 mm
- Electrical cable length 1.3 m
- Please reference the built-in dimensions provided in the installation drawings
- Not suitable for combination with gas hobs

Consumption Data

- Energy Efficiency Class: A (at a range of energy efficiency classes from A+++ to D)
- Power rating: 300 W
- Average Energy Consumption: 37.8 kWh/year*
- Blower Efficiency Class: A*
- Lighting Efficiency Class: -*
- Grease Filtering Efficiency Class: C*

* In accordance with the EU-Regulation No 65/2014

N 90, Downdraft hood, 90 cm, clear glass
198WMM1S1B

Dimensioned drawings

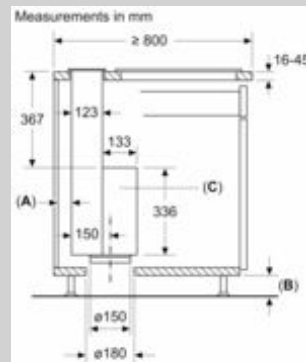
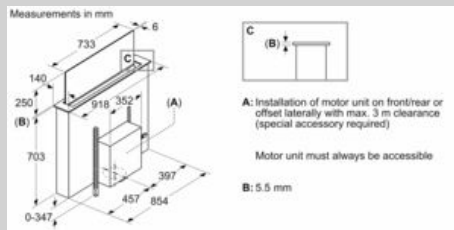

A: ≥ 20 mm between the Guided Air suction area and a cabinet wall

B: ≥ 60 mm for air recirculation

≥ 100 mm for air extraction with ducting in the plinth

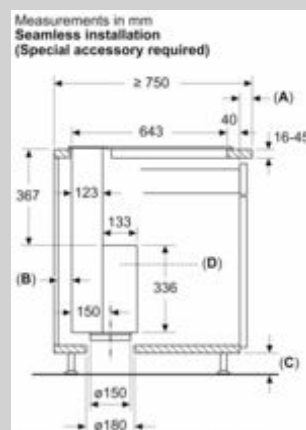
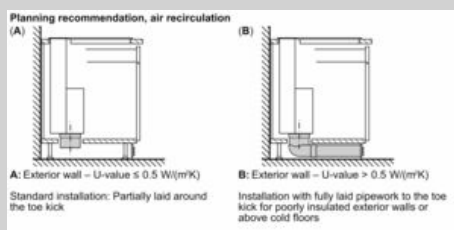
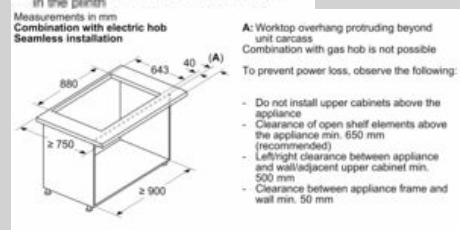
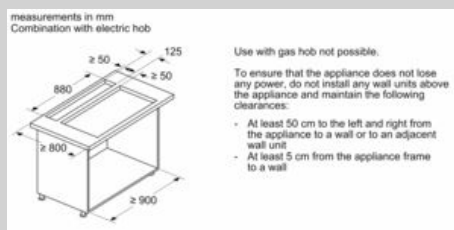

A: Worktop overhang protruding beyond unit carcass

B: ≥ 20 mm between the Guided Air suction area and a cabinet wall

C: ≥ 60 mm for air recirculation

≥ 100 mm for air extraction with ducting in the plinth

D: Motor unit must always be accessible