

# FISHER & PAYKEL

## SPECIFICATION GUIDE

## HEAT PUMP DRYER, 9KG SERIES 7



### OVERVIEW

With an efficient Energy Rating, this Heat Pump Dryer is Energy Star rated and designed to be placed almost anywhere in the home. Perfect for laundries where venting is difficult, heat pump technology dries at lower temperatures for gentle fabric care while condensing moisture. Pair with a matching washing machine for a clean, considered laundry.

### MODELS

Heat Pump Dryer, 9kg  
DH9060P2

### SERIES

Series 7  
Heat Pump Dryer

### FEATURES

- ① Designed to match with any Fisher & Paykel Front Loader Washing Machine
- ② Large 9kg capacity
- ③ Energy Star rated: 9 Star (AU/NZ), A++ (BI)
- ④ Easy installation with no need for external venting
- ⑤ Improved condensing efficiency and drying speeds
- ⑥ Low maintenance condenser with easy-to-clean foam filter
- ⑦ 14+ fabric care cycles including Delicate, Wool and Easy Iron
- ⑧ Auto-sensing technology detects moisture levels to prevent under or over drying
- ⑨ Drying rack for items that can't be tumble dried - perfect for delicates, shoes and toys
- ⑩ WiFi enabled, for ongoing improvements with software updates

### ACCESSORIES

- ① 1x Drying Rack
- ② 1x Drain Hose

# FISHER & PAYKEL

## SPECIFICATION GUIDE

## HEAT PUMP DRYER, 9KG SERIES 7

### SPECIFICATIONS

<b>Model No.</b>	DH9060P2
<b>Dimensions</b>	H 850mm W 600mm D 665mm
<b>Weight</b>	50kg
<b>Electrical</b>	
<b>Supply</b>	220-240V, 50Hz
<b>Service</b>	10-amp circuit
<b>Outlet</b>	3-prong grounding-type

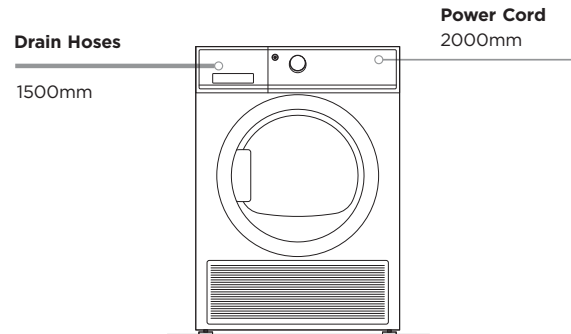

### PRODUCT DIMENSIONS

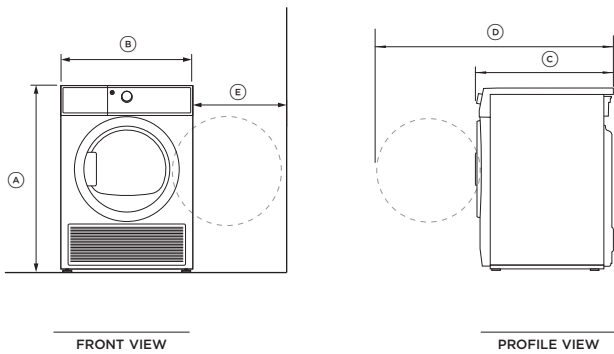

### CAVITY DIMENSIONS: STANDARD INSTALLATION

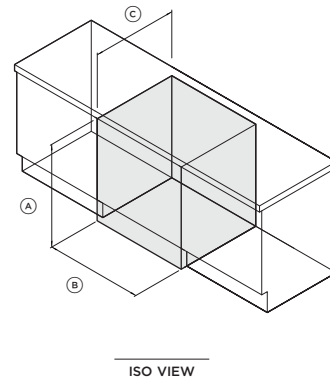

	mm
(A) Overall height*	min 840 max 855
(B) Overall width	600
(C) Overall depth**	665
(D) Depth with the door open	1080
(E) Door clearance to adjacent wall	min 335

\* Includes adjustable mounted feet and the range of movement

\*\* Includes dial and door when closed

	mm
(A) Overall height*	860
(B) Overall width	640
(C) Overall cavity depth	
• Flush with front panel of the product	640
• In cupboard	705
<b>Minimum gap clearance to adjacent product or cabinetry**</b>	20

\* Depends on feet adjustment

\*\* Applies to sides, top and rear