

N 70, 87.4 X 55.8 CM, SOFT CLOSE FLAT HINGE
G11216DE0



This built-in freezer helps to defrost faster and features a malfunction warning signal in case of increasing temperature.

- ✓ Low Frost – Reduces frost in the freezer compartment for faster defrosting
- ✓ Big Box – A roomy drawer for even more space for larger frozen items.
- ✓ Soft Close – Enjoy the silence. The door softly closes itself when at an angle of 20 degrees.

Energy Efficiency Class:E
 Average annual energy consumption in kilowatt hour per year (kWh/a): 176 kWh/a
 Sum of volume of frozen compartments: 96 l
 Airborne acoustical noise emissions : 36 dB(A) re 1pW
 Airborne acoustical noise emission class: C
 Thermometer freeze section:None
 Light: No
 Product category: Upright freezer
 Built-in / Free-standing: Built-in
 Door panel options: Not possible
 Frost free system:No
 Height of the appliance:874 mm
 Width of the appliance: 558 mm
 Depth: 545 mm
 Required niche size for installation (HxWxD): . 880 x 560 x 550 mm
 Dimensions of the packed product (HxWxD): . 950 x 620 x 640 mm
 Net weight: 39.8 kg
 Gross weight: 42.6 kg
 Connection Rating: 90 W
 Fuse protection:10 A
 Frequency:50-60 Hz
 Length electrical supply cord: 230.0 cm
 Door hinge:Right reversible
 Defrost: manual
 Warning signal / malfunction: Both visual and audible
 Door lock: No
 Number of drawers/baskets (Stck): 3
 Number of freezing flaps (Stck):0
 EAN code:4242004247623
 Brand:Neff
 Product name / Commercial code: G11216DE0
 Product category: Upright freezer
 Included accessories: 1 x ice cube tray

1 x ice cube tray

KF1213S0 Door panel with decor frame
 KF1213Z0 Door panel with decor frame



N 70, 87.4 X 55.8 CM, SOFT CLOSE FLAT HINGE
G11216DE0

Design features

Functions

- Fixed hinge
- lowFrost freezer - less ice build up, faster defrosting
- SuperFreeze function with automatic deactivation
- Electronic control (LED chain)
- Freezer malfunction warning signal: optical, acoustical

Food freshness system

- 3 transparent freezer drawers, 1 bigbox

Key features - Fridge section

- Right hinged door, reversible
- Connection value 90 W
- 220 - 240 V

Dimension and installation

- Dimensions: 87.4 cm H x 55.8 cm W x 54.5 cm D
- Niche Dimensions: 88 cm H x 56 cm W x 55 cm D

Key features - Freezer section

- ice cube tray

Included accessories

- KF1213S0, KF1213Z0

Design features

Dimension and installation

Country Specific Options

- Based on the results of the standard 24-hour test. Actual consumption depends on usage/position of the appliance.

Additional features

Performance and Consumption

- EU19_EEK_D: E
- Total Volume : 96 l
- Freezing capacity 24h : 5 kg
- Annual Energy Consumption: 176 kWh/a
- Climate Class: SN-T
- Noise Level : 36 dB , EU19_Noise emission class_D: C

N 70, 87.4 X 55.8 CM, SOFT CLOSE FLAT HINGE
G11216DE0

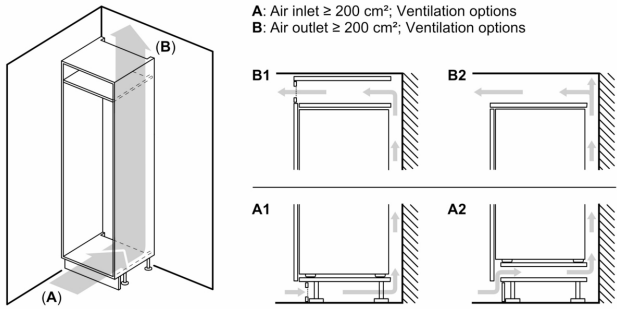

Maximal permissible weight of the unit fronts

Fitted unit fronts that exceed the permissible weight may cause damage and result in functional impairment of the hinges

A: Weight
A: Appliance door height including hinges in mm
B: Undamped hinge, unit front in kg
C: Damped hinge, unit front in kg
D: Additional possible load in kg with heavy load kit

A	B	C	D
1500-1750	22	22	B+5 / C+5
720-1400	19	19	
A1	15	19	
A2	15	19	

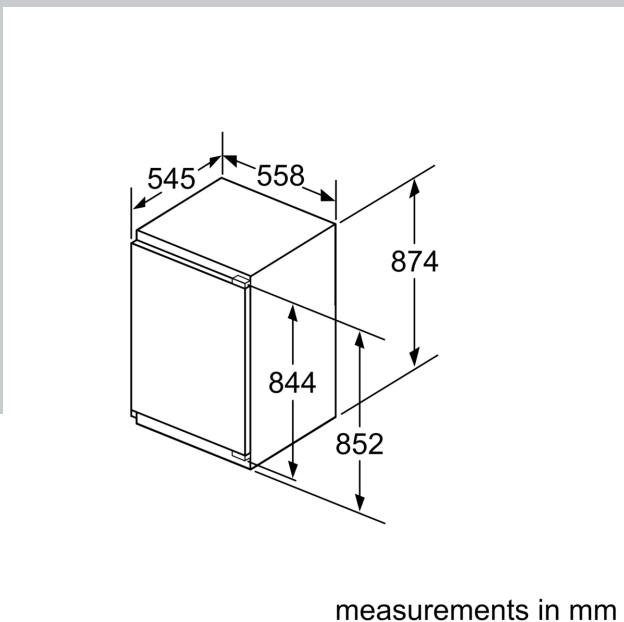
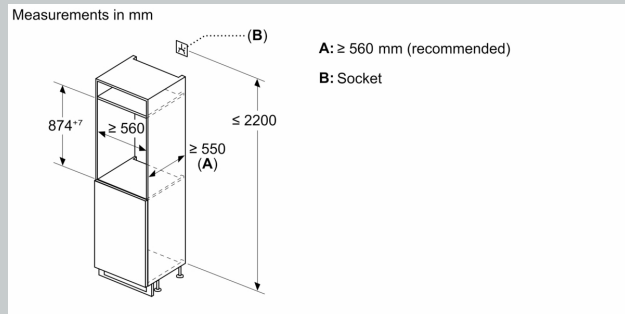
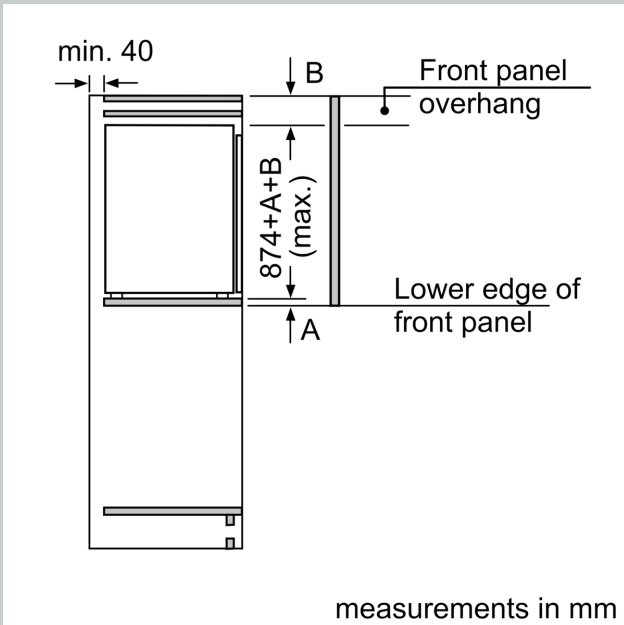

measurements in mm
Recommended gap dimensions for flat hinges

F	R	X
16-19	0-3	2.5
20	0-1	3
	2-3	2.5
21	0-1	3
	2-3	2.5
22	0	4
	1	3.5
	2-3	3

The gap dimensions recommended in the table must be adhered to in order to ensure that appliance doors do not collide with anything when they are opened, and to avoid causing damage to kitchen units.